

AP17B - DATASHEET

TECHNICAL FEATURES

Max. Diameter:	36,7 mm
Max. Height:	28,2 mm
Weight:	2,7 ± 0,1 g
Volume:	12660 mm ³

CAPSULE MATERIALS

Capsule body:	PBT
Color:	Propylene masterbatches, metallic possibility (requirements FDA for food contact)

STOCKING

Store in a dry place, with temperatures not higher than 40°C and not less than 2°C, with humidity 30 - 75%.

EXTRACTED COFFEE THF

After 12 months value gets 20% lower than limitations allowed by law.
(0,6 mg/kg)

SEALING FEATURES

Capsule is sealable with:	Polypropylene, filter paper, aluminum with thermolacquer
Sealing temperature range:	270° - 300°*

- Approved for food contact
- Great oxygen barrier properties
- Perfect aroma preservation
- Great resistance to water vapor

PACKING

Capsules are packed into HDPE bags and contained in carton boxes whose quantity is 4250 pieces/carton box, then stacked on a Euro-pallet containing 15 carton boxes.

APPROVALS

0,001 ml/pkg • 24h • air (reference value
~ 0 aluminum ~ 0,070 polypropylene)

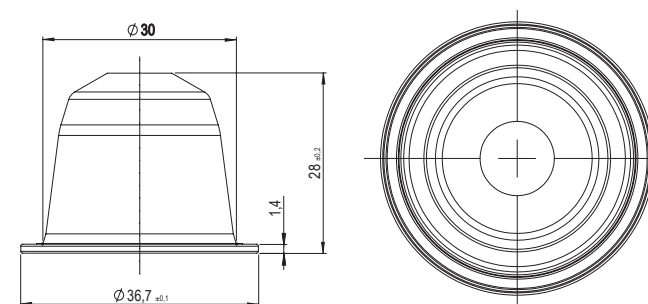

APPROVALS

Community Regulation 1935/2004
Community Regulation 2023/2006
Community Regulation 10/2011

The reference product, hereunder named Product, only contains monomers, additives and other starting substances authorized by the Commission Regulation (EU) n° 10/2011 of 14/01/2011.

1.1. The intentionally added substances not listed in the Annex I of Regulation (EU) n° 10/2011 meet the relevant requirements of Regulation (CE) n° 1935/2004 of the European Parliament and the Council of 27th October 2004 and a risk assessment was made in accordance with Article 19 of the Regulation (EU) 10/2011. With reference to the Regulation (CE) n° 1935/2004, we confirm that the Product was produced in accordance with the Manufacturing Practices (according to Article 3 of the Regulation (CE) n° 1935/2004 and following specifications of Regulation 2023/2006) and that traceability as required by Art. 17 of this Regulation is ensured by the indication of the lot number and the production site number that are marked on the identification label.

1.2. The intermediate products of reaction, decomposition or reaction products meet the relevant requirements of Regulation (CE) n° 1935/2004 and a risk assessment was made in accordance with Article 19 of the Regulation (EU) n° 10/2011.

*depending upon the type of material it is sealed to and the time/cycle of temperature.